

## Baureihe 49-TH - Type 49-TH

2/2 - Wege Magnetventil für Mediumtemperaturen bis + 200°C

2/2 - way solenoid valve for temperatures up to +200°C

### Standardtype

Ventil in Ruhestellung geschlossen - (NC). Der erregte Magnet öffnet eine Vorsteuerbohrung und hebt direkt oder unterstützt von der Druckdifferenz den Kolben vom Hauptsitz. Das Ventil schließt durch Federkraft.

### Standard type

Valve non-energised closed by spring power - NC. When energised, the solenoid will open/free the pilot chamber and the valve will open directly or servo assisted by the pressure differential ( $\Delta p$ ) of the flow medium. A pressure differential ( $\Delta p$ ) is not required for the operation.



Steuerungsart: type of control:	zwangsgesteuert force pilot operated	metall. Innenteile: metallic internals:	Messing und Edelstahl 1.4104 brass and stainless steel (AISI 304)
Konstruktion: construction:	Kolbensitzventil piston design	Dichtung: seal:	PTFE PTFE
Anschluß: connection:	G1/4-G3, DIN ISO 228 G1/4-G3, DIN ISO 228	Einbaulage: installation:	nur mit stehendem Magneten actuator only in upright position
Druck: pressure:	0-40 bar (s. Tabelle) 0-40 bar (see table)	Anschlußspannung: supply voltage:	AC: 24,110,230V 50Hz DC: 24,110,205V=
Durchflußmedium: medium:	neutrale, gasförmige u. flüssige Medien neutral, gaseous and liquid medium	Spannungstoleranz: voltage tolerance:	+5% / -10% +5% / -10%
Viskosität: viscosity:	50mm <sup>2</sup> /s 50mm <sup>2</sup> /s	Leistungsaufnahme: power-consumption:	T322 = 21 Watt T242 = 26 Watt T272 = 60 Watt T352 = 80 Watt
Mediumtemperatur: medium temperature:	-10 bis +180°C (Option -EL +200°C) -10 up to +180°C (option -EL +200°C)	Schutzart: enclosure standard:	IP65 nach DIN 40050 IP65 according to DIN 40050
Umgebungstemperatur: ambient temperature:	+35°C +35°C	Einschaltdauer: operating factor:	100% ED-VDE 0580 100% ED-VDE 0580
Ventilgehäuse: body material:	../10../.. = Messing / brass ../08../.. = Edelstahl 1.4581 / stainless steel (AISI 316 Ti)	Kabelanschluß: electric connection:	Klemmkasten terminal box

TH = Temperatureausführung +180°C - Magnetspule wird über einen separaten Gleichrichter betrieben.

TH = high temperature design up to +180°C - solenoid with external rectifier.

EL = Temperatureausführung +200°C - Magnetspule wird über eine separate Schaltelektronik betrieben.

EL = electric device for higher pick up power for +200°C - solenoid with separate electric device.

EL nur in 230V 50-60Hz möglich, nicht in NO-Ausführung / EL only available in 230V 50-60Hz and not in NO.

G	Sitz orifice mm	Kv-Wert flow-rate m <sup>3</sup> /h	Standardtype standard type PN40	max. Druck bei Magnettype max. pressure regarding solenoid type			
				T322-TH	T242-TH	T272-TH	T352-TH
1/4	13	1,8	E4921/1004/....	0-10	0-40	-	-
3/8	13	4,0	E4922/1004/....	0-10	0-40	-	-
1/2	13	4,5	E4923/1004/....	0-10	0-40	-	-
3/4	25	11,5	E4924/1004/....	0-6	0-25	0-40	-
1	25	13,0	E4925/1004/....	0-6	0-25	0-40	-
5/4	40	29,0	E4926/1004/....	0-6	0-20	0-40	-
6/4	40	33,0	E4927/1004/....	0-6	0-20	0-40	-
2	50	49,0	E4928/1004/....	-	0-6	0-13	0-40
2½	62	58,0	E4929/1004/....	-	-	0-10	-
3	76	60,0	E4930/1004/....	-	-	0-10	-

Stückliste - parts list

- K1.1 Armatur / valve body
- K2.1 Deckel / bonnet
- \*K3.1 Vorsteuersitz / rough control seat
- \*K3.2 Ventilkolben komplett / valve piston
- \*K3.3 Führungsstern / guide star
- \*K3.4 Vorsteuerspindel / rough control spindle
- \*K3.5 Ventilteller / valve disk
- \*K3.7 Überwurfmutter / cap nut
- \*K3.8 Kolben / piston
- K3.11 Zwischenverschraubung / screw joint
- K3.13 Dämpfungsschraube / muting screw
- K3.14 Scheibe / disk
- \*K3.17 Führungsband / guide band
- \*K3.18 O-Ring / o-ring
- \*K3.19 O-Ring / o-ring
- \*K3.20 O-Ring / o-ring
- \*K3.21 O-Ring / o-ring
- \*K3.22 O-Ring / o-ring
- \*K3.23 O-Ring / o-ring
- K3.27 6-kt. Mutter / hexagon nut
- K3.28 6-kt. Mutter / hexagon nut
- \*K3.33 Feder / spring
- K5.1 Magnethülse / solenoid tube
- K5.2 Magnetanker / solenoid anchor
- K5.4 Druckstück / pressure part
- K5.5 O-Ring / o-ring
- K5.6 Scheibe / disk
- K5.8 Zylinderschraube / cylinder screw
- K5.9 Scheibe / disk
- K6.1 Magnetspule / solenoid
- K7.1 Klemmkasten / terminal box

\* = Bestandteil des Ersatzteilkäppchens  
(je nach Ausführung freibleibend)  
\* = all components of spare parts and  
service sets are variable in reference to  
different versions and executions. (These  
specifications are without obligation).

Baureihe / type E4921-E4925

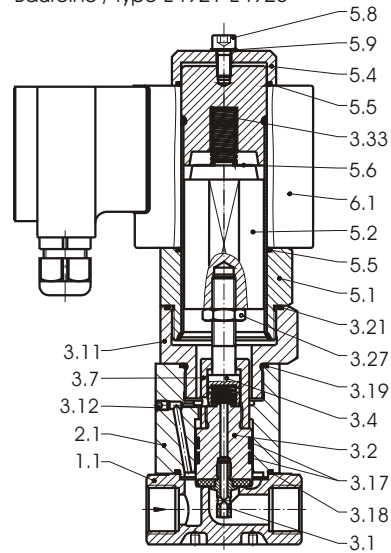

Baureihe / type E4926-E4928

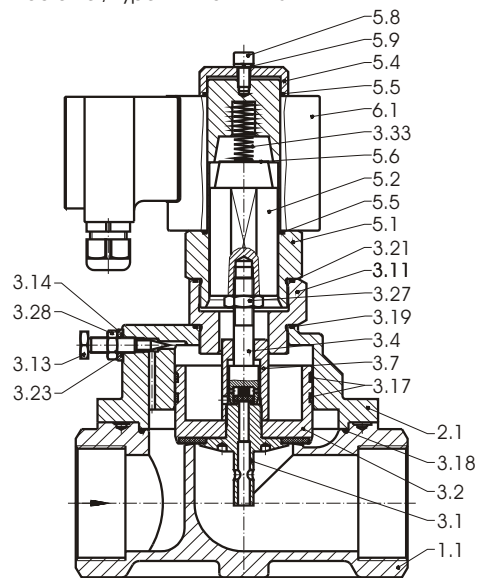

Baureihe / type E4929-E4930

